

RISER SECTION

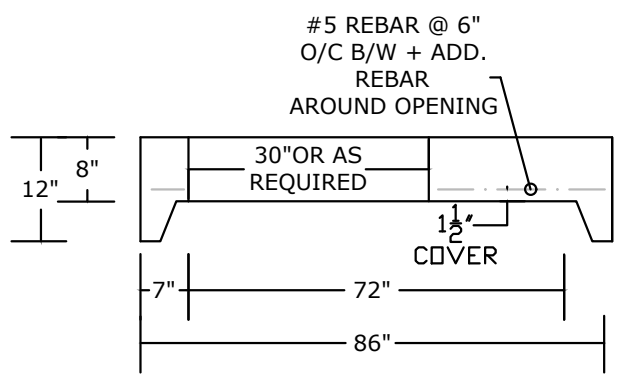

FLAT TOP SIDE VIEW

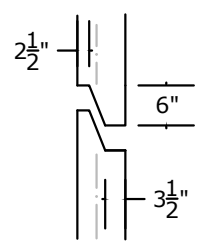

JOINT DETAIL

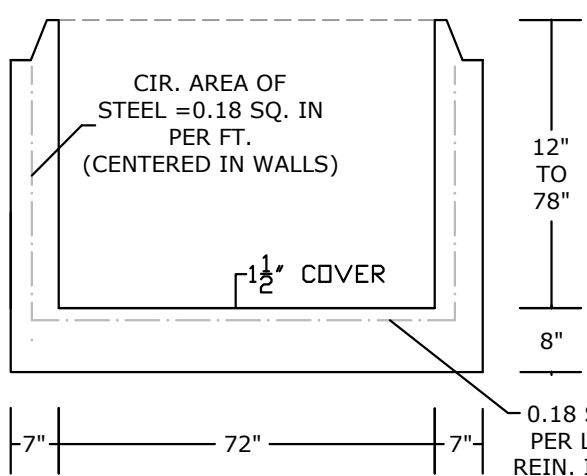

BASE SECTION

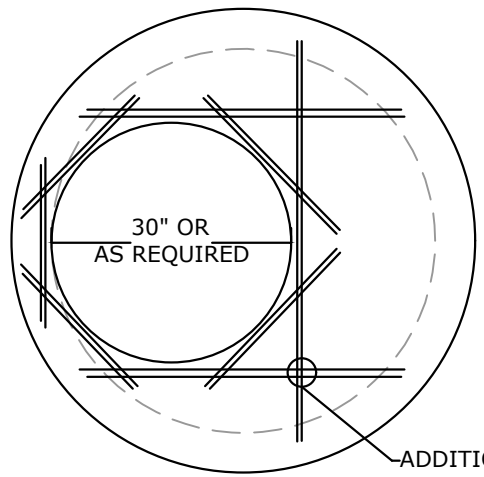

FLAT TOP PLAN VIEW

0.18 SQ. IN. PER LIN. FT REIN. IN BOTH DIRECTIONS (BASE)

NOTES:

- HS-25 LOAD RATED
- CONCRETE 5,000 PSI @ 28 DAYS
- REINFORCING: AS SPECIFIED, GRADE 60 REBAR
- 8" BASE WEIGHT: 5,000 LBS.
- WEIGHT PER V.F.: 1,800 LBS.
- FLAT TOP WEIGHT: 5,000 LBS.
- MANUFACTURED IN ACCORDANCE WITH ASTM C-478
- STEPS: 12" O/C - STEEL REINFORCED POLYPROPYLENE COATED, DOT APPROVED

PEERLESS CONCRETE PRODUCTS CO.		246 Main Street Butler, NJ 07405 973.838.3060p	
SINCE 1959		www.peerlessconcrete.com	
sales@peerlessconcrete.com		www.peerlessconcrete.com	
72" DIAMETER STORM MANHOLE			
CUSTOMER:			
PROJECT:			
SCALE: N.T.S.	DATE: 12/2023	EST#:	D-8